

# MICROFINISH BALL VALVES

## INSTALLATION OPERATION AND MAINTENANCE MANUAL



**MICROFINISH VALVES PVT. LTD.** 

Block no.23B, Plot no.1 to 6, Hubballi-Dharwad Bypass Road, Itigatti Village,  
Dharwad-580 114, Karnataka state, India. Phone: +91 836 2310015 / 16 / 19  
Email: sales@microfinishgroup.com Website: www.microfinishgroup.com

**THE AMERICAS**

**MICROFINISH VALVES, INC.** 

7505 Bluff Point Drive, Suite 100 Houston, Texas 77086, United States.  
Phone: +1 281-885-4250 / +1 281-885-4259 Fax: +1 281-866-0996  
Email: usasales@microfinishgroup.com Website: www.microfinishvalvesinc.com

## INTRODUCTION

Microfinish Ball Valves have been designed and manufactured to give you long, excellent and trouble free service.

This manual provides you with all the relevant information to install, operate and maintain the valve for long trouble free life. **Please note that all the drawings provided in this manual are typical views.**

### 1.0 PRIOR TO INSTALLATION

- 1.1 On receipt of material check for any damage during transportation.
- 1.2. Wrapping and protection applied should be left in place until the valve is installed.
- 1.3. If the valves are left exposed, they should be protected against entry of foreign material in the valve parts.
- 1.4. Flush the pipe clean before mounting the valve in the pipeline. Impurities such as sand and parts of welding electrodes could damage the ball surface and the seats.
- 1.5. If the valves are stored for a long time, they should be cleaned, lubricated and tested prior to installation. It is advisable to store the valve in full open position.
- 1.6. In Lever operated valve, the position of Handle is an indication of whether the valve is open or closed. When the Handle is aligned with axis of the pipe the valve is open. When it is Perpendicular to the pipe, the valve is closed.
- 1.7. Duly packaged and in dry condition.
- 1.8. To be stored in normal atmospheric temperature.
- 1.9. Indoor storage, not to be stored at outside with direct sun light.
- 1.10. If stored for long time, the seat permanent set may happen, some periodical open and close operation test may be performed to avoid this issue.
- 1.11. Proper lubrication to be done before application, as applicable.
- 1.12. No other extra lever is to be used to operate the valve, which enhance input force other than the MVPL-provided levers or Hand-wheel.
- 1.13. Please use recommended lever length or Hand-wheel diameter to operate the valve.

### 2.0 INSTALLATION

#### CAUTION

The valves should be used in a well-designed, adequately supported piping system such that it will not be subjected to undue forces, stresses or shock loads during service. The valves are not designed to operate during or after earthquakes or under fatigue conditions. It is the responsibility of the owner to determine if fatigue conditions exist.

- 2.1.** The valve may be installed in any position, however avoid stem position downwards. It is recommended to mount the valve having stem in horizontal position.
- 2.2.** Valve should not carry the weight of the piping. Proper support of the pipeline will minimize strain on the valve caused by shock in the pipe system. The valve can be supported by its body with pipe clamps and supports. Do not fasten supporting structure to the valve flanges.
- 2.3.** Do not attempt to correct pipe misalignment by means of flange bolts.
- 2.4.** Do not allow the valves to carry the weight of pipeline to avoid distortion and jamming.

- 2.5. If necessary, tighten the gland packing uniformly during the trial operation of the valve.
- 2.6. A qualified welder must perform all welding operations and the welding procedure shall be in accordance with ASME Boiler & Pressure Vessel Code Section IX.
- 2.7. When mounting the screwed end, butt weld end, socket weld end and flanged end type valves the following respective procedures must be followed, for better performance.

## **2.8. SCREWED END VALVE INSTALLATION**

- 2.8a. Clean both the mating parts before assembly.
- 2.8b. Sealant if necessary should be applied only to the pipe or male threads.
- 2.8c. Use correct size wrenches with flat jaws on hexagon or octagon ends.
- 2.8d. Do not use undersized threads on section of pipe where the valves are to be installed.

## **2.9. BUTT WELD END VALVE INSTALLATION**

- 2.9a. Keep the valve in 'Full Open' position.
- 2.9b. Space the joint apart, co-axially with a 2 to 3 mm gap.
- 2.9c. Use an internal welding backing ring where practical.
- 2.9d. After finishing the welding operation clean the pipeline and valve parts by flushing or pigging to remove the impurities formed during welding.
- 2.9e. Do not allow rapid application of excess welding material.
- 2.9f. Do not allow the temperature of valve body seat area to exceed 120° C (248° F) to prevent seat and seal damage.
- 2.9g. When butt weld end valves are purchased with no extended nipple, before welding, remove the central body assembly along with ball and seats, place a spacer of same dimensions and then weld the ends.

## **2.10. SOCKET WELD END VALVE INSTALLATION**

- 2.10 a. Keep the valve in 'Full Open' position.
- 2.10 b. First insert the pipe to full depth of socket then pull out about 1.5mm and weld.
- 2.10c. Provide adequate support to the pipe on each side or to the valve prior to welding.
- 2.10d. Weld each end of the valve with a continuous bead. The welding rod should not exceed 3.2 mm diameter.
- 2.10e. Remove the spacer and reassemble the valve body assembly when the system cools down to ambient temperature.
- 2.10f. Do not allow the temperature of valve body seat area to exceed 120° C (248° F) to prevent seat and seal damage.
- 2.10g. When butt weld end valves are purchased with no extended nipple, before welding, remove the central body assembly along with ball and seats, place a spacer of same dimensions and then weld the ends.

## **2.11. FLANGED END VALVE INSTALLATION**

- 2.11a. Be sure that flange gaskets and fasteners are suitable for the operating conditions.
- 2.11b. Insert the valve (fully open position) along with suitable gasket between the mating flanges, align the flange bolt holes & hold it in place.
- 2.11c. Hold the nuts first on backside of the valve flange and then insert the bolts.
- 2.11 d. Tighten all the bolts to finger tight.
- 2.11 e. Use two spanners to tighten the joint, in the sequence as shown in Figure.

# BOLTING SEQUENCE CHART

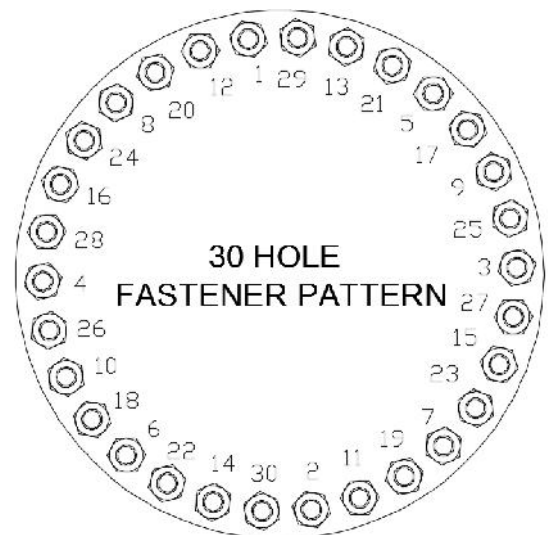
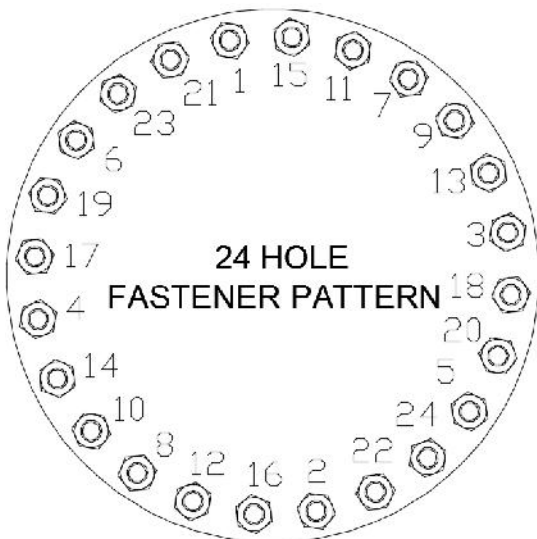
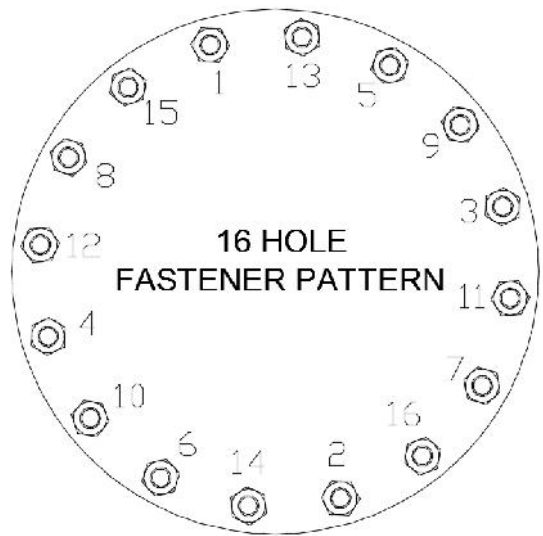
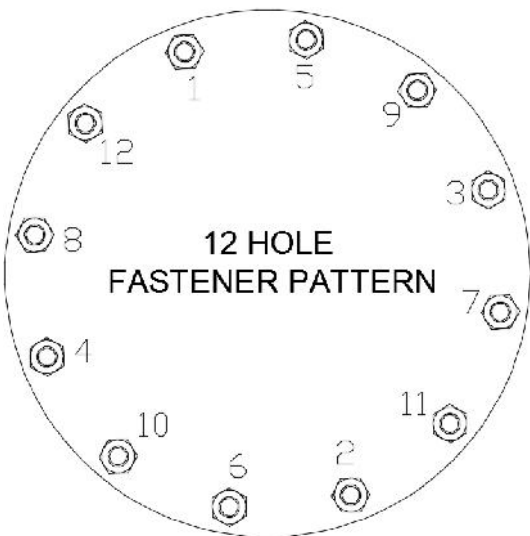
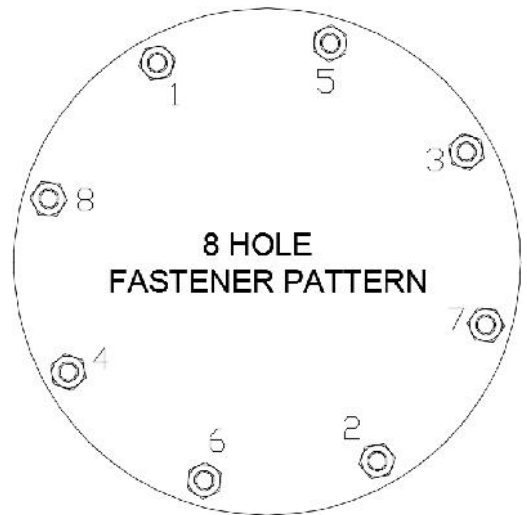
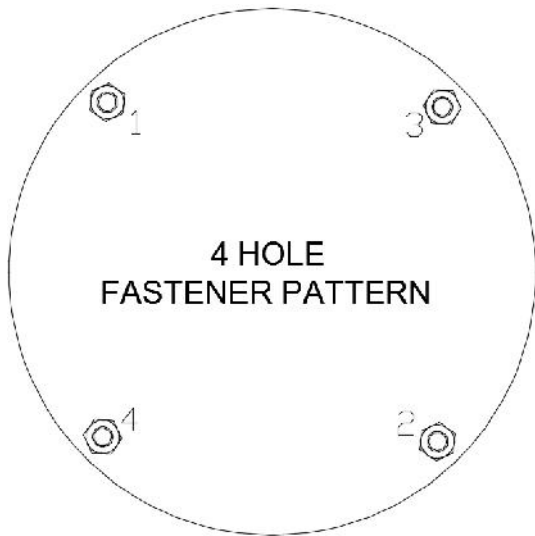

## TIGHTENING TORQUES FOR FASTENERS

Thread size x Pitch	Tightening Torque for lubricated fasteners				Tightening Torque for Dry fasteners							
	N-m		lbf-in		N-m		lbf-in					
M5x0.8	3	to	4	27	to	35	4	to	5	35	to	44
M6x1	5	to	6	44	to	53	7	to	9	62	to	80
M8x1.25	11	to	14	97	to	124	16	to	20	142	to	177
M10x1.5	22	to	24	195	to	212	30	to	33	266	to	292
M12x1.75	37	to	39	327	to	345	51	to	54	451	to	478
M14x2	55	to	57	487	to	504	81	to	85	717	to	752
M16x2	83	to	87	735	to	770	123	to	130	1089	to	1151
M20x2.5	165	to	170	1460	to	1505	240	to	250	2124	to	2213
M24x3	275	to	290	2434	to	2567	410	to	430	3629	to	3806
M27x3	415	to	438	3673	to	3872	618	to	650	5465	to	5753
M30x3	555	to	585	4912	to	5178	825	to	870	7302	to	7700
M30x3.5	540	to	570	4779	to	5045	800	to	840	7081	to	7435
M33x3	745	to	785	6594	to	6948	1115	to	1170	9869	to	10355
M33x3.5	740	to	775	6550	to	6859	1100	to	1155	9736	to	10223
M36x3	975	to	1025	8629	to	9072	1460	to	1535	12922	to	13586
M36x4	935	to	985	8275	to	8718	1390	to	1455	12303	to	12878
M39x3	1260	to	1325	11152	to	11727	1890	to	1985	16728	to	17569
M42x3	1570	to	1650	13896	to	14604	2360	to	2475	20888	to	21906
M42x4.5	1490	to	1560	13188	to	13807	2210	to	2320	19560	to	20534
M48x3	2380	to	2500	21065	to	22127	3585	to	3765	31730	to	33323
M48x5	2220	to	2335	19649	to	20666	3305	to	3470	29252	to	30712
M52x3	2170	to	2279	19207	to	20168	4555	to	4785	40315	to	42351
M52x4	2195	to	2305	19427	to	20399	4395	to	4615	38899	to	40846
M56x3	2697	to	2832	23868	to	25061	5610	to	5890	49653	to	52131
M56x4	2766	to	2904	24480	to	25704	5725	to	6010	50671	to	53193
M60x3	3988	to	4187	35296	to	37061	6965	to	7310	61645	to	64699
M60x4	4711	to	4946	41695	to	43780	7070	to	7425	62575	to	65717
M64x3	4852	to	5095	42948	to	45095	8300	to	8715	73461	to	77134
M64x4	4711	to	4946	41695	to	43780	8615	to	9050	76249	to	80099
M72x3	6939	to	7285	61411	to	64482	12350	to	12970	109307	to	114794
M80x3	9113	to	9569	80656	to	84689	16240	to	17050	143736	to	150905
M90x3	13092	to	13746	115874	to	121662	24403	to	25624	215985	to	226792

## **2.12. THREE PIECE VALVE DESIGN WITH WELD-END CONNECTIONS WELDING INSTRUCTIONS**

### **2.12.1. General**

Please follow the welding instructions and safety precautions carefully before installing Microfinish valve. Spare body seals are provided as part of the valve package, only Microfinish spare parts shall be used.

The working area must be clean and clear from dirt and debris that might contaminate the valve internals. Flush the pipeline from dirt, and weld spatter before valve installation commence.

Standard valves are bi-directional and may be installed in either direction.

Valves with pressure relief hole in the ball are unidirectional and must be installed with the flow arrow pointing the pipeline low pressure side.

### **2.12.2. DISMANTLING**

2.12.2.1 With the valve in the open position, remove body bolts and separate the valve center section from its tail-piece (ends).

2.12.2.2 Remove the ball seats and body seals; place the ball seats on a clean surface and discard the used body seals.

2.12.2.3 Turn the valve handle to the closed position and slide out the ball. Place the ball on a clean surface.

### **2.12.3. WELDING**

2.12.3.1 Reassemble the tail-piece (ends) to the valve body with two bolts (studs) and nuts.

2.12.3.2 Align the valve with the pipeline, ensure proper fit to minimize pipe load.

2.12.3.3 Tack-weld the tail-piece (ends) to the pipeline.

2.12.3.4 Dismantle the valve fasteners and remove the valve body (see figure A).

2.12.3.5 Place all parts on a clean surface.

2.12.3.6 Protect the body connectors sealing faces from welding splatter and complete the welding.

2.12.3.7 Allow adequate time for cooling and then flush the pipe line.

### **2.12.4. ASSEMBLY**

2.12.4.1 With the valve in the closed position, carefully slide the ball into the body. Note: The ball will key into the stem only if the valve is in the closed position.

2.12.4.2 Turn the valve to the fully open position.

2.12.4.3 Place the new body seals and the ball seats inside the body.

2.12.4.4 Ease the body center section between the tail-piece (ends).

2.12.4.5 Care must be taken not to score the tail-piece faces or damage the seals.

2.12.4.6 Insert the body bolts (or studs) & nuts into the valve.

2.12.4.7 Tighten the nuts & body bolts according to torque figures shown in table 1, and tightening pattern shown in figure B.

2.12.4.8 Keep the valve in the open position until flushing process is completed.

### 2.12.5. FLUSHING THE PIPELINE

It is an important precaution taken to prevent damage to valve ball and seats. While flushing, keep all valves in the fully 'open' position, to allow dirt, sand, grit, welding slag or other debris to be flushed thoroughly from the pipeline. When the flushing media is clean, the valves can be shut off. Actuated valves in the fail-safe 'closed' position, should be activated to the 'open' position during the flushing procedure.

### 2.12.6. IN-LINE WELDING

In general Microfinish recommends the use of valves with extended-pups which are designed for in-line welding.

### 2.12.7. ADVANTAGES:

- 2.12.7.1 Reduced installation time.
- 2.12.7.2 Valve integrity is kept as per factory procedures.
- 2.12.7.3 Maintain valve cleanliness (i.e. Oxygen service).

### 2.12.8. When welding a valve in-line, certain precautions are required:

- 2.12.8.1 Keep the valve in the open position throughout the complete installation process.
- 2.12.8.2 Flush the pipeline properly before activating the valve.

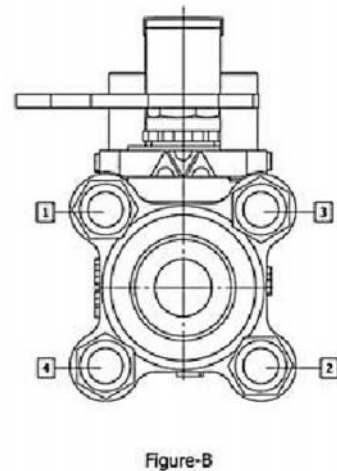
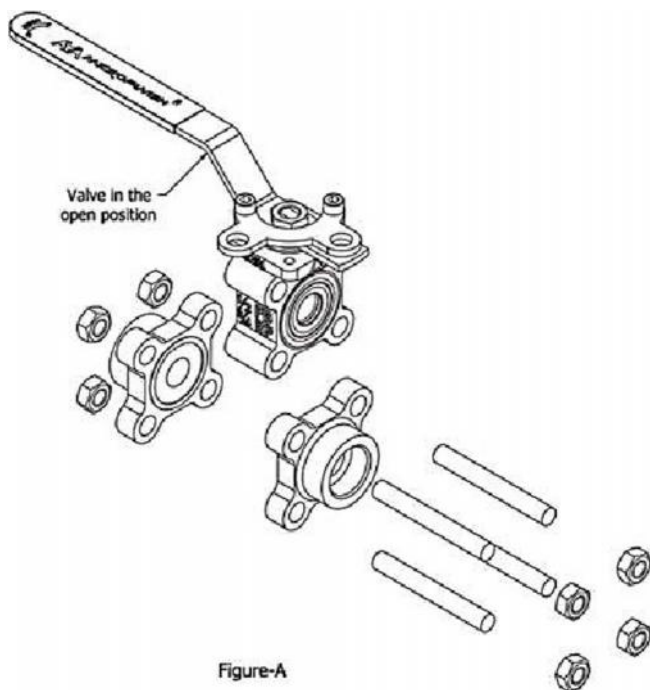

### 3.0 OPERATION AND MAINTENANCE

- 3.1 Flush the pipeline carefully once more when the valves are mounted to remove all the possible impurities. Before flushing keep the valve open fully.
- 3.2 Valves should be opened and closed slowly to avoid hammering effect on the valve and pipeline.
- 3.3 Valve should be "fully opened" or "fully closed" to prevent damage to the seat and ball caused by wire drawing.
- 3.4 If valve is intended for on-off service only, it should not be used for throttling services.
- 3.5 If stem leak develops, tighten the gland nut until leakage has been stopped. If the stem leak cannot be stopped then replacement of stem packing is necessary.
- 3.6 If a through leak occurs, ensure that the valve is fully closed. Don't use extra leverage or extra force on the stem to prevent leakage. If leakage persists, replacement of seats is necessary.
- 3.7 After a long service life, when through valve leakage is observed, the seats can be interchanged.
- 3.8 The ball valve needs no regular maintenance or lubrication.
- 3.9 Replacement of stem packing:  
When replacing the packing, be sure that the valve is not under pressure. Remove all accessories including actuator to give access to the packing. After loosening and removing the gland nut, the packing can be removed by means of a hooked wire.
- 3.10 Do not try to correct the through valve leakage by giving packing pieces behind the seat to make it tight. Instead replace the seat.
- 3.11 If a body seal leak develops, do not over tighten the body end cover studs and nuts. This may damage the valve. Instead body seal should be removed and replaced by new one.
- 3.12 **Sealant Injection feature in Trunnion Mounted Ball Valves:** Secondary sealant injection system is used only when damage has been caused to the seat rings or stem seals by the hard particles or dirt in the process media and a temporary tight shut off is required for maintenance or other purpose. Use standard grades of the valve sealants, which are suitable for the media in the valve. Sealant is to be pushed with a hand pump on the seat surface through the sealant injection port provided on the valve body and stem housing. Prior to injecting sealant, flush the sealant port with suitable valve cleaner. This will purge old sealant and debris if any, from the valve seats.

Procedure for emergency sealant injection.

**Note:** Sealant injection is to be carried out only if the valve seats or stem packing are leaking.

Trunnion mounted pipeline valves of sizes 6" NB and above are provided with two sealant injection ports on the body/body adapter for individual seats and one sealant injection port on the stem housing. Each port provided on the body provides sealant entry to the valve seats. The port provided on the stem housing provides sealant entry to the stem sealing area. The ports are fitted with double-check one piece fitting.

**Injecting Handgun: Sealant** is injected by connecting the outlet fitting of the handgun to the sealant injection port.

Sealant should be injected only when the valve is in closed position to ensure effective

sealing of damaged seat.

Refer sealant injection fitting arrangement is shown in Figure No. 01. Slide the giant button head coupler which is integral with the hose of sealant injection gun, over a double - check one-piece fitting. Now the arrangement is ready for injection of the sealant.

After the completion of sealant Injection operation, slide away the giant button head coupler, which is integral with the hose of sealant Injection gun from the double-check one piece fitting.

**FIGURE: 01 Sealant Injection Fitting Arrangement**

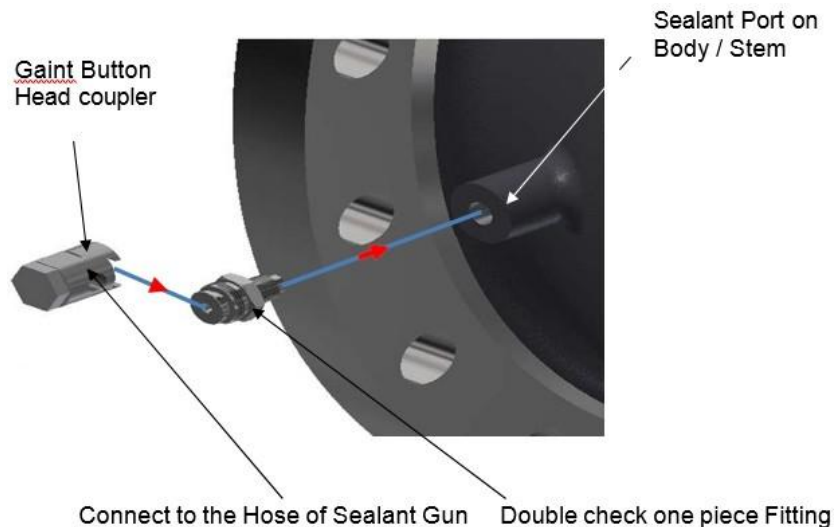

**CAUTION!**

**Injection Pressure;**

1. Min. injection pressure shall be 1.1 times the actual working line pressure.
2. Max. injection pressure shall be 1.5 times the actual working line pressure but should not exceed the Maximum Cold Working Pressure for the body/bonnet material.

Same is applicable when the sealant extension lines are provided.

**3.13 Stem packing adjustment;**

- a. Microfinish valves include the feature of an externally adjustable stem seal in the event there is leakage experienced from the stem area.
- b. If possible, relieve any pressure within the valve during the adjustment process. If this is not possible, it is still safe to perform this adjustment on a valve in the field.
- c. Operate the valve once in the No load condition.
- d. Loose the Gland Nut / Chuck Nut for 2 rounds.
- e. Operate the valve for 3 times.
- f. Tight the Gland Nut / Chuck Nut as per Table (01) column "X".
- g. Again loose the Gland Nut / Chuck Nut.
- h. Operate the valve for 3 times.
- i. Retighten the Gland Nut / Chuck Nut as per Table (01) column "Y".
- j. Operate the valve for 3 times.
- k. Record the No load torque.

- I. If this first action has not stopped the leak, repeat steps “d” to “j”. Only perform this adjustment action a maximum of 3 times. If the leakage has not stopped after three attempts, stop the test as further attempts could be detrimental to elements of the stem packing system.

<b>BALL VALVE CHECK NUT TIGHTENING TORQUE (Nm)</b>				
<b>CHECK NUT SIZE</b>	<b>GRAPHITE</b>		<b>PTFE</b>	
	<b>X</b>	<b>Y</b>	<b>X</b>	<b>Y</b>
M10x1.5	10	5	9	5
M12x1.25	15	7	13	5
M18x1.5	19	11	17	11
M22x2	22	19	20	15
M30x2	29	19	27	18
M40x2	34	22	32	20
M48x2	60	38	40	50
M60x2	70	47	90	70
M68x2	80	70	120	90
M74x2	90	82	140	100

**Table No. 01 Check Nut Tightening Torque**

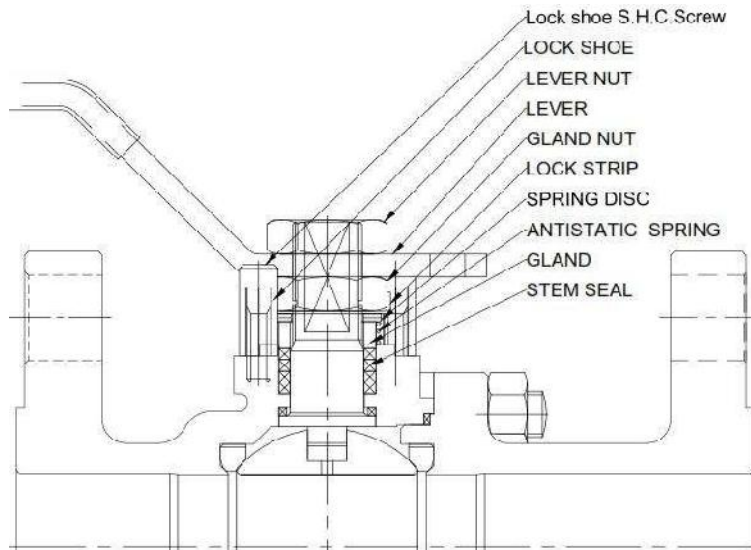

For smaller valves with a double nut design, the Gland nut is held in place by a locking strip. The adjustment of the stem seal to tighten the packing cannot be carried out while this locking clip is firmly in place. It first needs to be loosened by pulling back the tabs from the nut with a flathead screwdriver, so the nut can be rotated and reset the stem seal. When the action is complete, you need to re-secure the locking strip to the nut by pushing back up the tabs.

## 4.0 DISASSEMBLY

**For your safety and protection, it is important that the following precautions be taken prior to removing the valve from service or before any disassembly of the valve.**

### 4.1 DISASSEMBLY FROM PIPE LINE

- 4.1 a Keep hands out, since remotely actuated valves could close at any time. Disconnect all auxiliary piping of jackets and pneumatic or electric connections.
- 4.1 b Wear any protective clothing or equipment normally required when working with media involved.
- 4.1 c De-pressurize all the lines and drain the system fluid. Cycle the valve several times to relieve any pressure still inside the valve
- 4.1 d Keep the valve in full open position. Remove the valve and place it on a level surface in vertical position.

## **WARNING!**

**VALVES SHALL NOT BE DISMANTLED IN CLOSED POSITION**

### 4.2 DISASSEMBLY OF THE FLOATING VALVE (REFER FIGURE-2)

- 4.2 a Flush the valve to remove the residuals in the valve.
- 4.2 b Support the valve on a platform.
- 4.2 c Remove all accessories if fitted and also adapter, lever or gear operator.
- 4.2 d Remove check nut / gland nut, spring, locking plate and gland.
- 4.2 e Unscrew the body end connection studs and separate the body and end pieces/tail piece.
- 4.2 f Place the disassembled parts on clean wooden or cardboard surface. Do not keep ball and seats on cement or metal surfaces to avoid damage.
- 4.2 g Take out the seat rings and body seal. Body seal to be replaced during re-assembly.
- 4.2 h Keep the valve in CLOSED position and remove the ball.
- 4.2 i Push the stem into the body cavity and then takeout through the end port. Remove the stem washer and stem seal.
- 4.2 j Clean all parts carefully. If necessary use suitable solvent.
- 4.2 k Check all the sealing surfaces and parts for damage or uneven wear. Minor scratches or flashes on the ball surface can be removed using a fine abrasive cloth.
- 4.2 l Check the condition of the stem.

### 4.3 DISASSEMBLY OF TRUNNION MOUNTED VALVE – 2PC(REFER FIGURE-3 and 4)

- 4.3 a Follow the points in clause 4.2a to 4.2c
- 4.3 b Remove lever / adapter or gear operator and bracket.
- 4.3 c Remove check nut, spring disc, gland and anti-static spring.
- 4.3 d Remove stuffing box, stuffing bearing and stuffing box seal.

- 4.3e Pull the stem from top and take out. Remove anti-static spring, stem washer and stem seals.
- 4.3f Remove trunnion and trunnion seal.
- 4.3g Unscrew the body end connection studs and separate the body and tailpiece.4.3h Remove seat retainer from tailpiece and seat springs.
- 4.3g Remove the ball from body and also remove trunnion bearing and thrust washer.4.3h Remove seat retainer from body and springs.
- 4.3i Place all parts on clean soft surface. Do not keep the parts on cement or metal surfaces to avoid damage.
- 4.3j Clean all the parts carefully. If necessary use suitable solvent.
- 4.3k Check all the sealing surfaces and parts for damage or uneven wear. Minor scratches or flashes on the ball surface can be removed using a fine abrasive cloth.
- 4.3l Check for the wear or any damage at all the sealing area of stem, ball, seat, bearings and stuffing box bore. Correct / replace the damaged parts if necessary.

#### **4.4 DISASSEMBLY OF TRUNNION MOUNTED VALVE - 3PC.** (REFER FIGURE-05)

- 4.4 a Follow the points in clause 4.3a to 4.3c
- 4.4 b Remove lever / adapter or gear operator and bracket.
- 4.4 c Remove gland flange.
- 4.4 d Remove stuffing box, stuffing bearing and stuffing box seal.
- 4.4 e Push the stem from top and take out from bottom. Remove anti-static spring, stem washer and stem seals.
- 4.4 f Remove ball support bottom plate, ball support washer and ball bearing.\
- 4.4 g Unscrew the body end connection studs and separate the body and both tailpieces.
- 4.4 h Remove seat holder & seat retainer from tailpiece.
- 4.4 i Remove the coil springs.
- 4.4 j Remove the ball from body.
- 4.4 k Place all parts on clean soft surface. Do not keep the parts on cement or metal surfaces to avoid damage.
- 4.4l Clean all the parts carefully. If necessary use suitable solvent.
- 4.4m Check all the sealing surfaces and parts for damage or uneven wear. Minor scratches or flashes on the ball surface can be removed using a fine abrasive cloth.
- 4.4n Check for the wear or any damage at all the sealing area of stem, ball, seat, bearings and stuffing box bore. Correct / replace the damaged parts if necessary.

## **5.0 ASSEMBLY**

Using the parts contained in complete repair kit, reverse the disassembly procedure. Never reuse Packing, Body Seals, Stem Seal, Stem Washer and dispose the material as per the local government rules in such manner they could not affect the environment.

All the material used for packing of the product such as wood & plastic etc. shall be reused or disposed as per local government rules.

In case of damage / wear / corrosion to the parts of the valve, they need to be replaced during re-assembly and handover the damaged parts to authorized agency for reuse or dispose, so that damaged parts could not affect the environment.

When the valve is declared as scrap handover the valve / E-waste to authorized agency for reuse or dispose, so that scrapped valve could not affect the environment.



# TRUNNION MOUNTED BALL VALVE

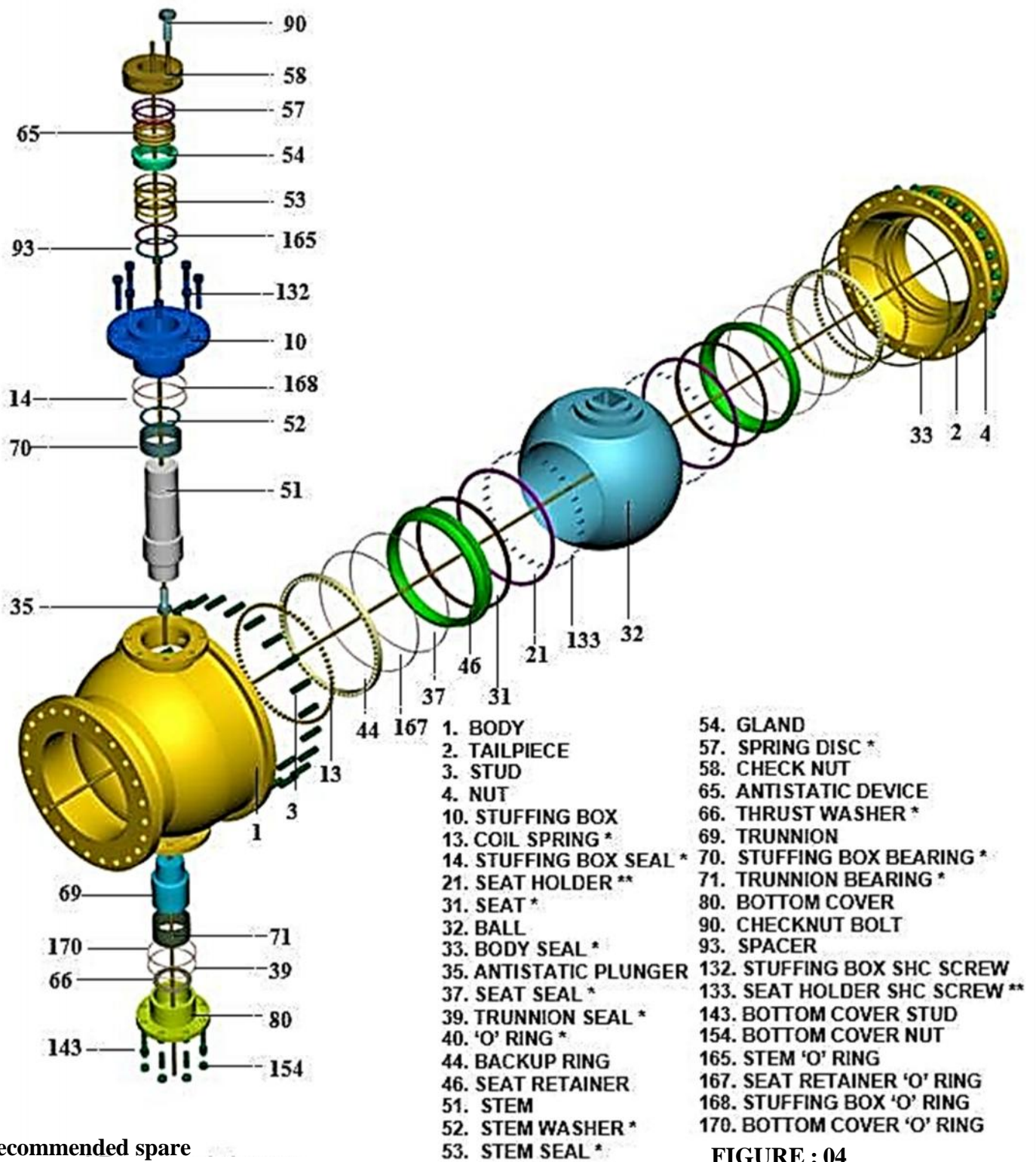

\*Recommended spare

\*\* Applicable for sizes 12" & above

FIGURE : 04

**TRUNNION MOUNTED BALL VALVE  
(THREE PIECE DESIGN)**

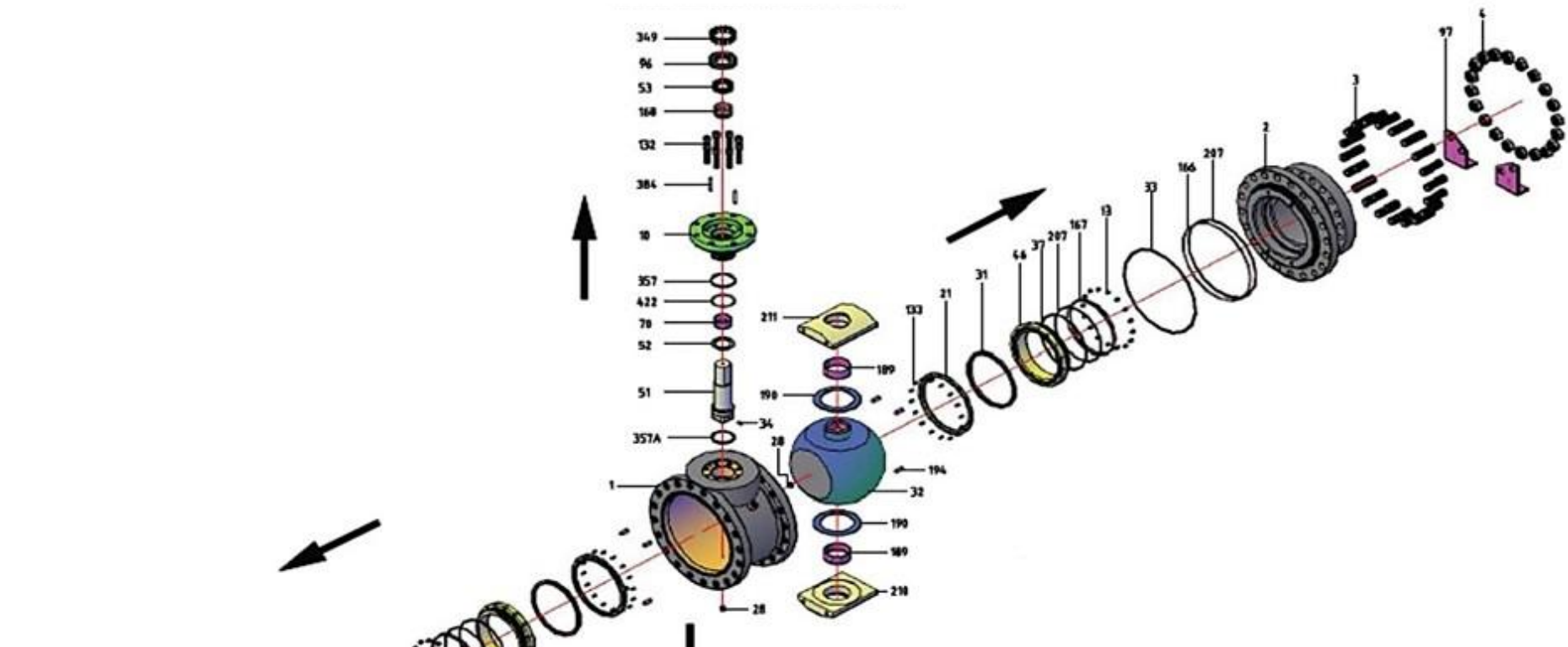

- 1. BODY
- 2. TAILPIECE
- 3. STUDS
- 4. NUTS
- 10. STUFFING BOX
- 13. COIL SPRING
- 21. SEAT HOLDER
- 28. DRAIN AND VENT PLUG
- 31. SEAT
- 32. BALL
- 33. BODY SEAL
- 34. ANTISTATIC STEM SPRING
- 37. SEAT SEAL
- 46. SEAT RETAINER
- 51. STEM
- 52. STEM WASHER
- 53. STEM SEAL
- 70. STUFFING BOX BEARING
- 96. GLAND FLANGE
- 97. VALVE SUPPORT
- 118. LIFTING PLATE
- 132. STUFFING BOX S. H. C SCREW
- 133. SEAT HOLDER S. H. C SCREW
- 166. TAILPIECE 'O' RING
- 167. SEAT RETAINER 'O' RING
- 168. STUFFING BOX 'O' RING-1
- 189. BALL BEARING
- 190. BALL SUPPORT WASHER
- 194. DOWEL PIN
- 207. 'O' RING BACK UP RING
- 210. BALL SUPPORT BOTTOM PLATE
- 211. BALL SUPPORT TOP PLATE
- 349. STUFFING BOX AND GLAND FLANGE S. H. C. SCREW
- 357. STUFFING BOX SEAL
- 357A. STUFFING BOX WASHER
- 384. DOWEL PIN-1
- 422. STUFFING BOX 'O' RING-2

# PRESSURE – TEMPERATURE RATINGS FOR FLOATING BALL VALVE SEAT MATERIALS

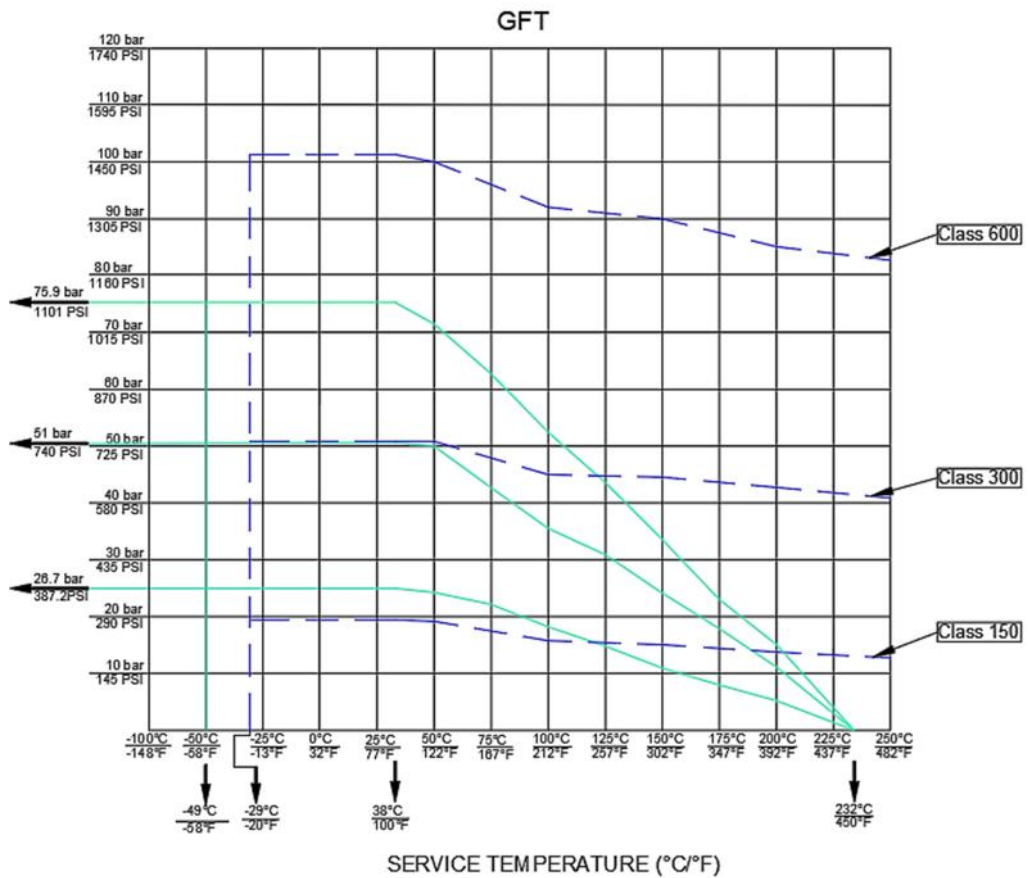
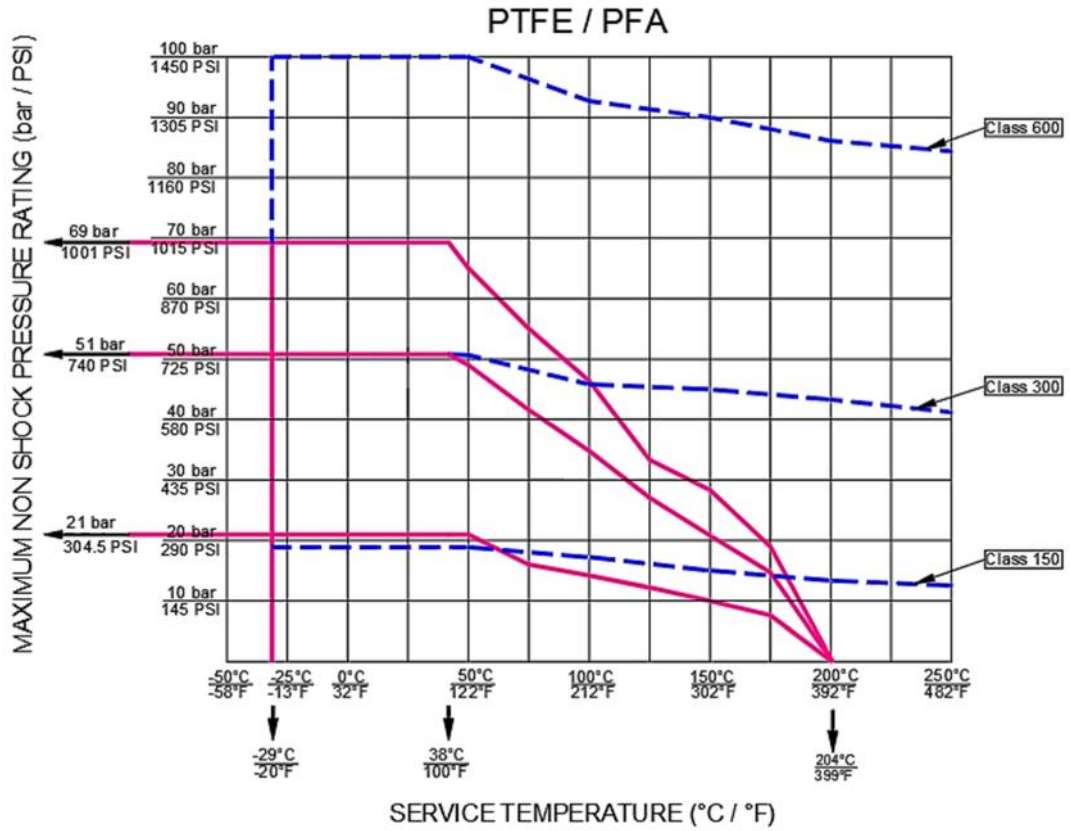

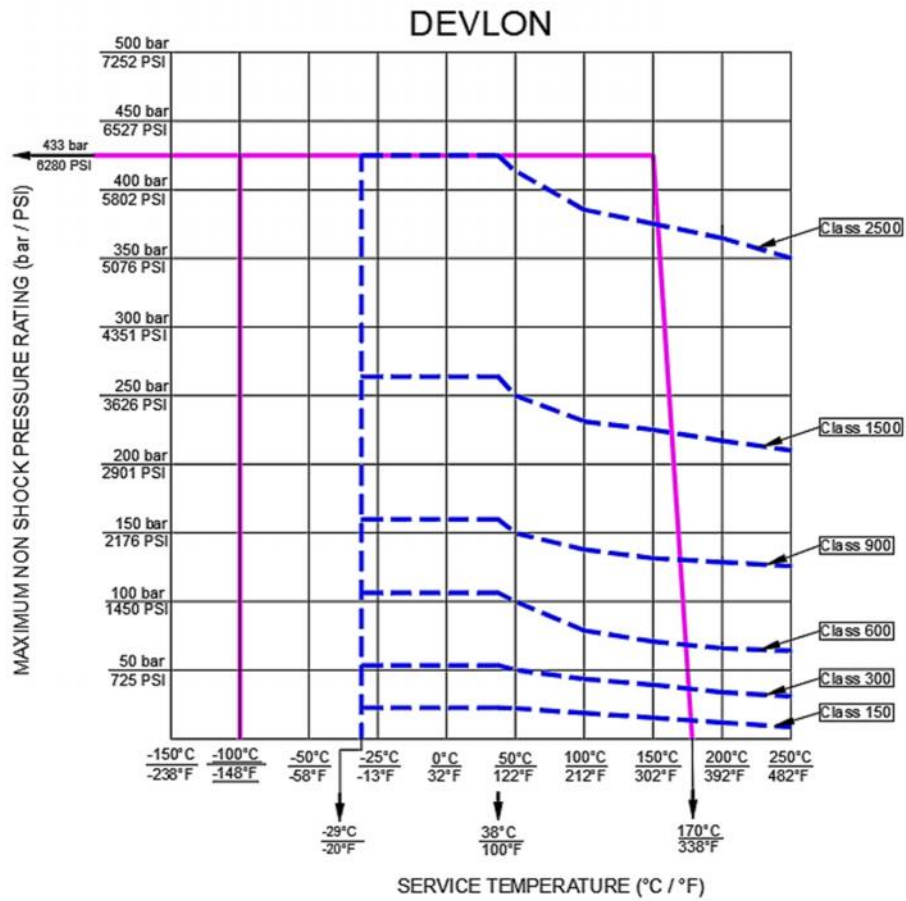
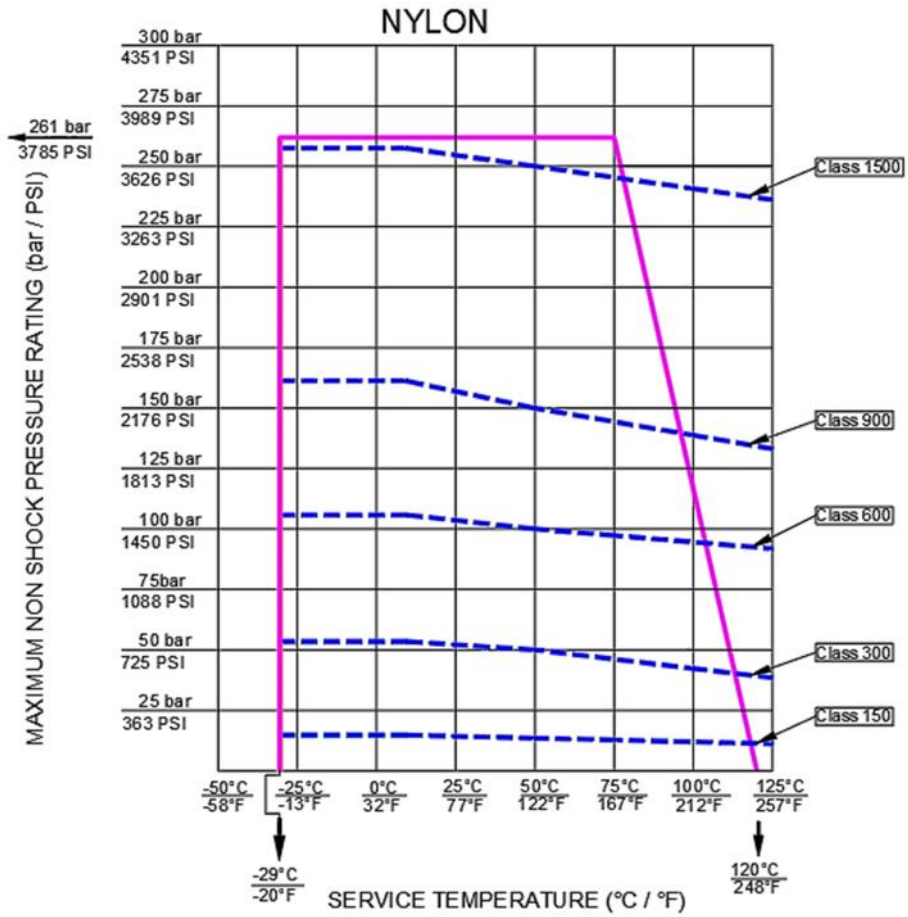

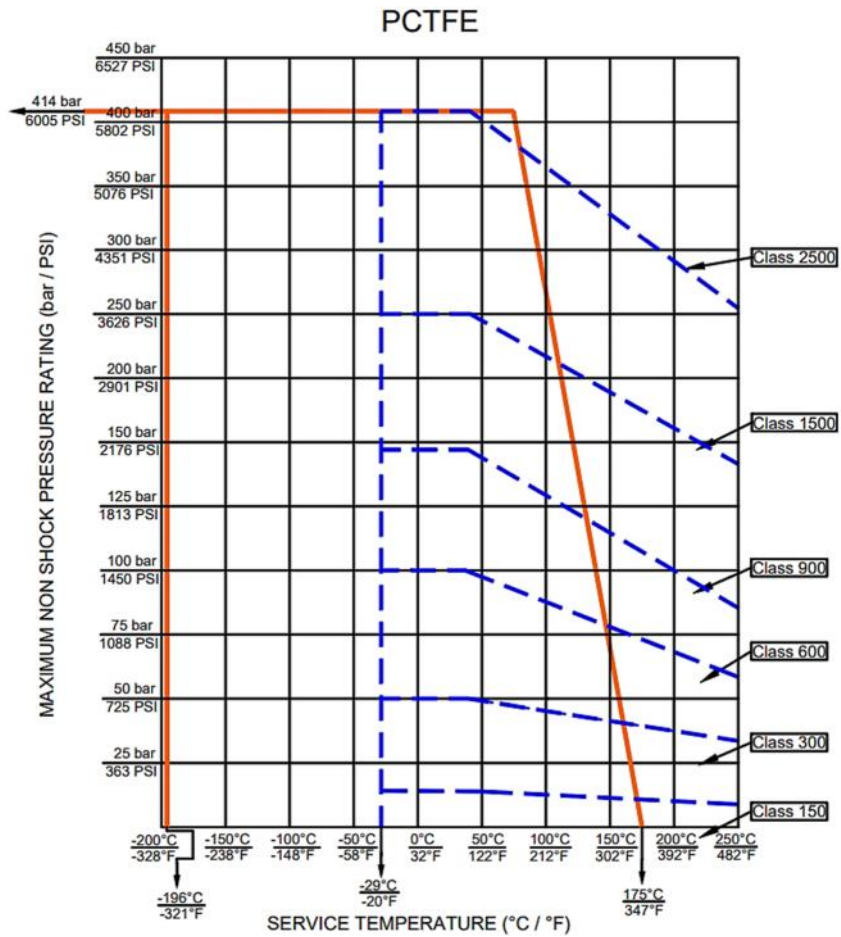
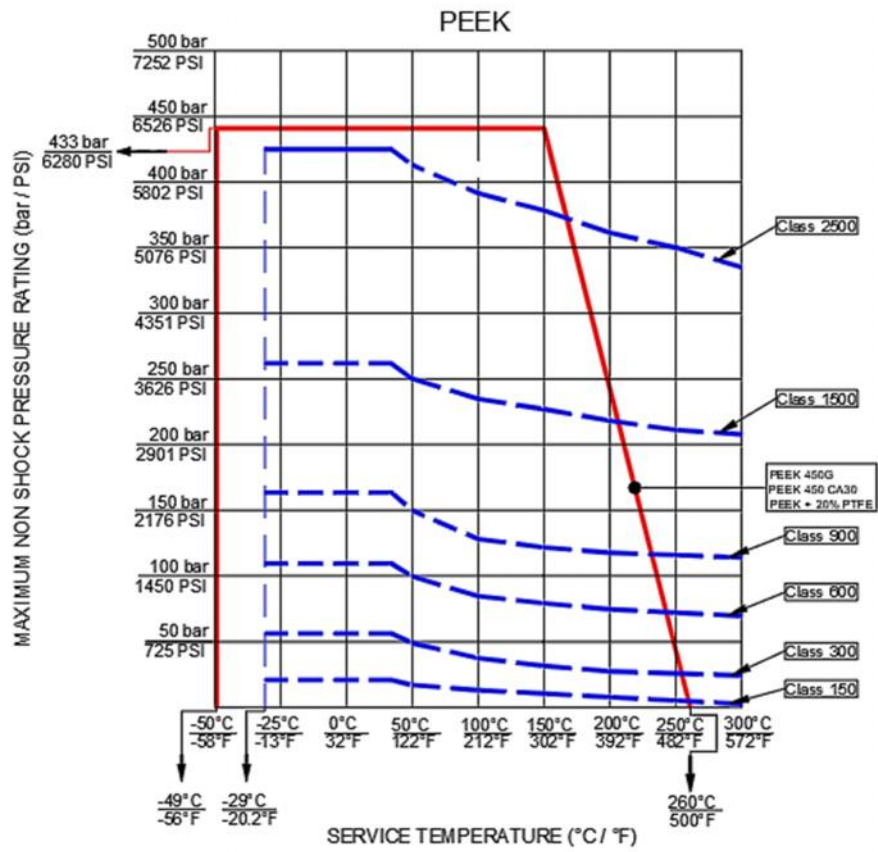

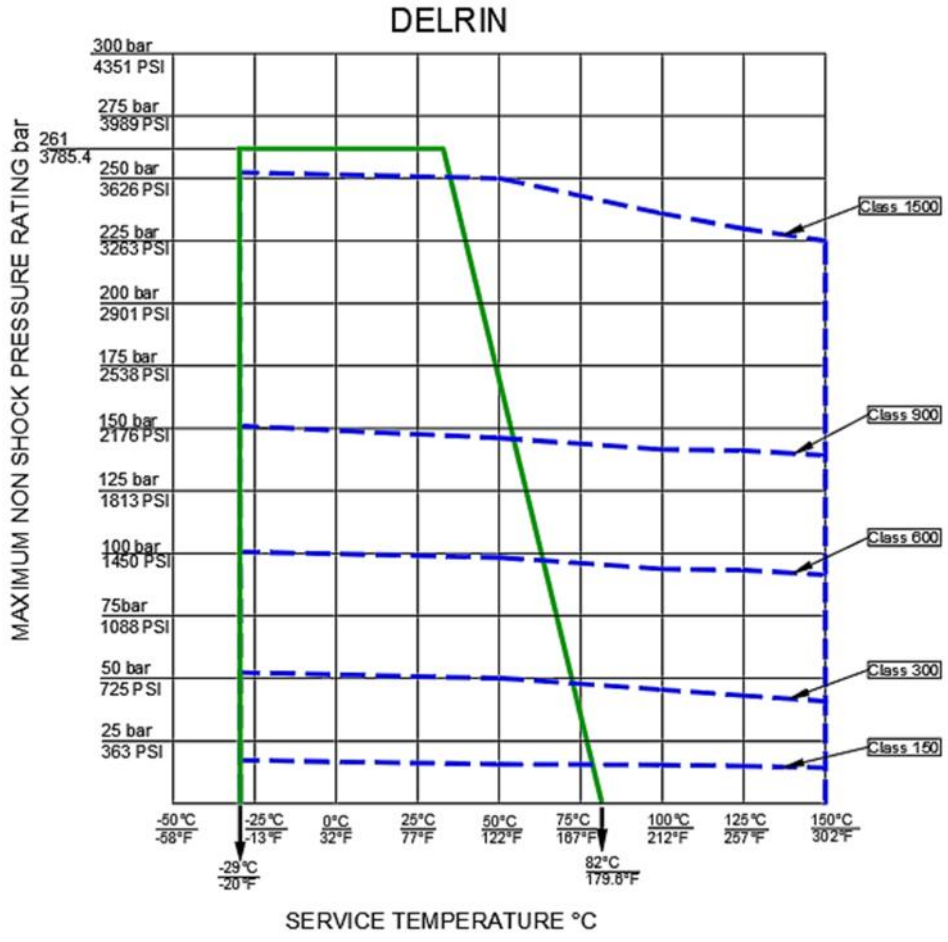
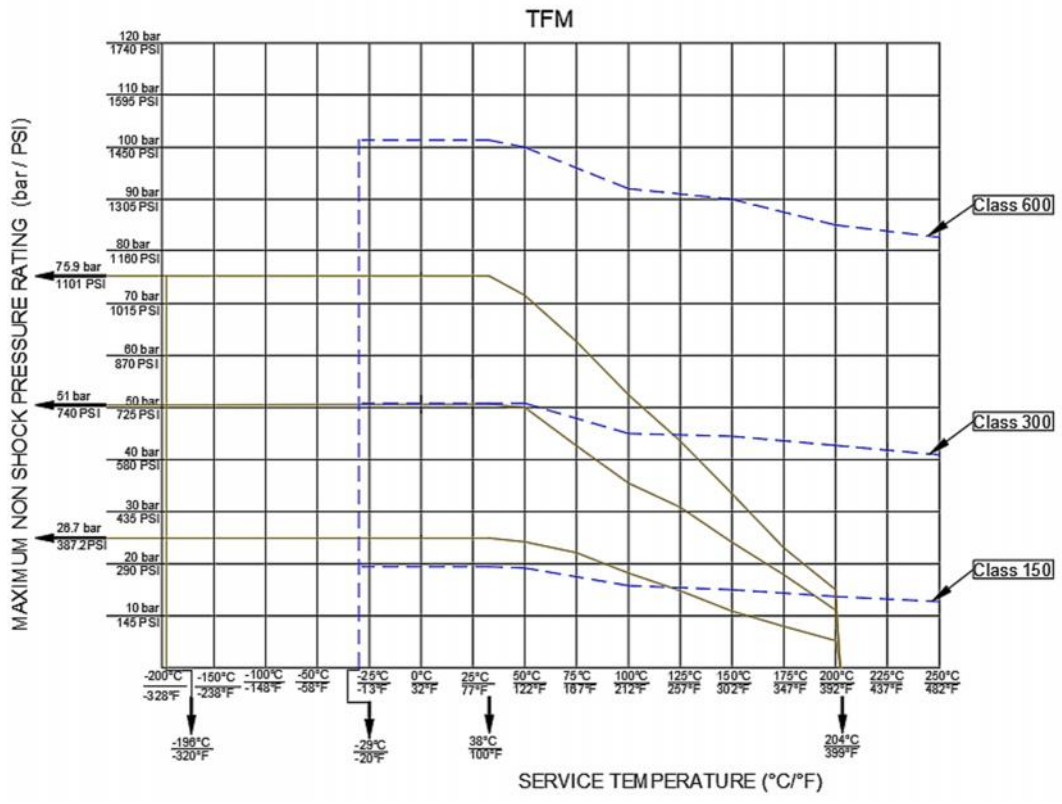

### CFT/RTFM

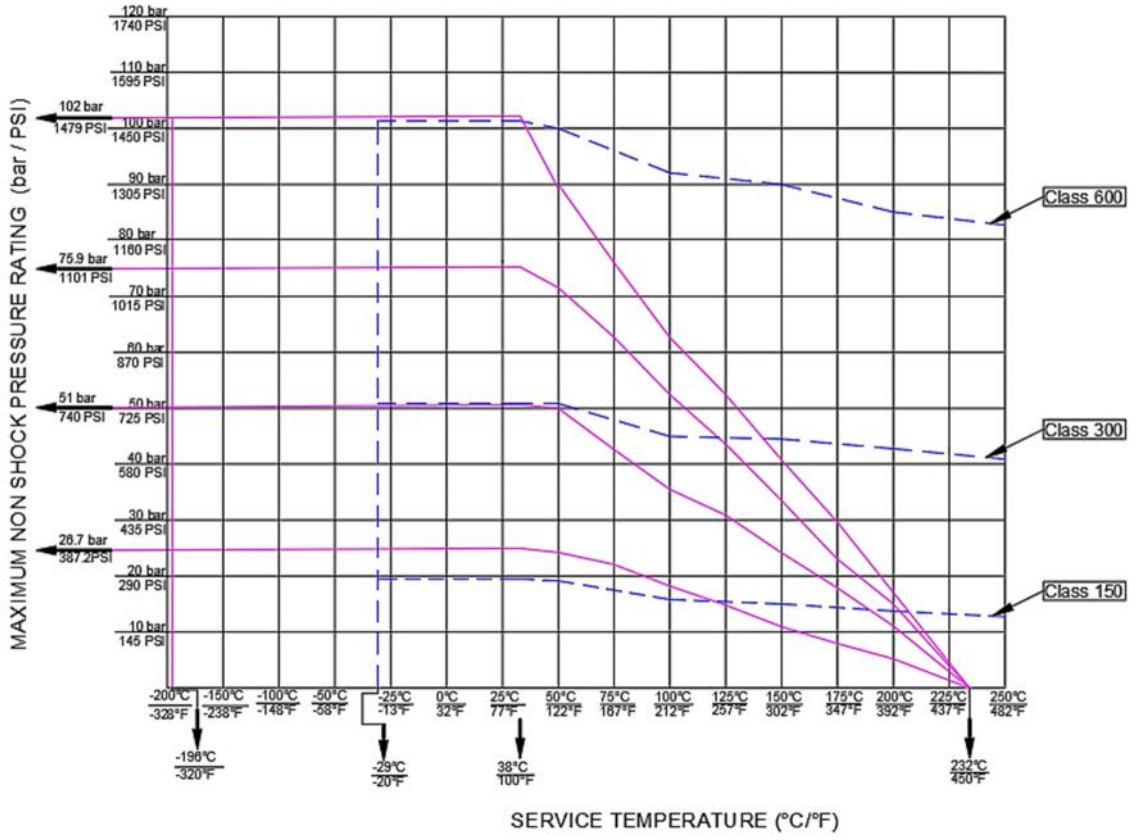

# PRESSURE – TEMPERATURE RATINGS FOR TRUNNION MOUNTED BALL VALVE SEAT MATERIALS

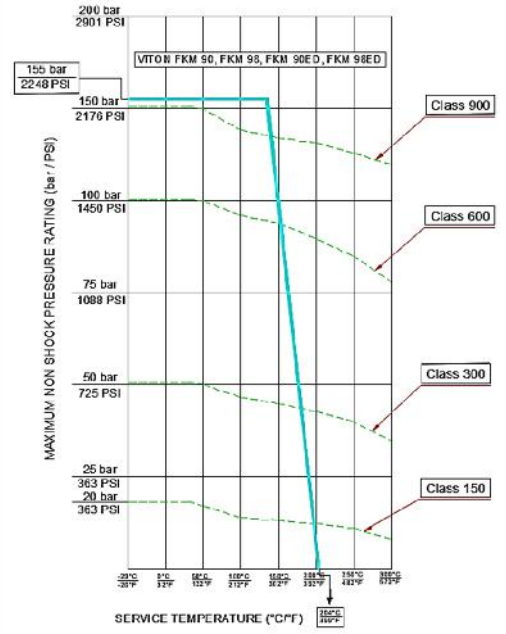
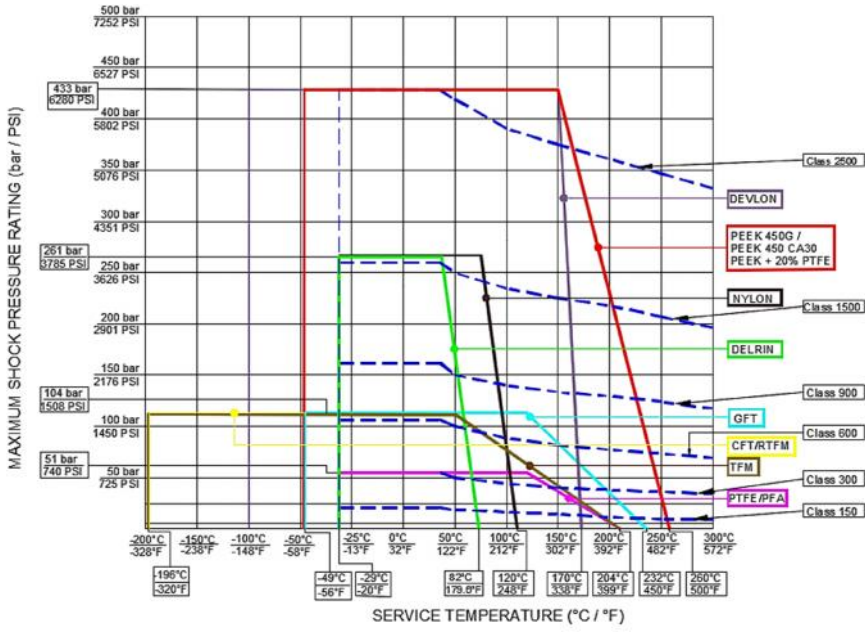



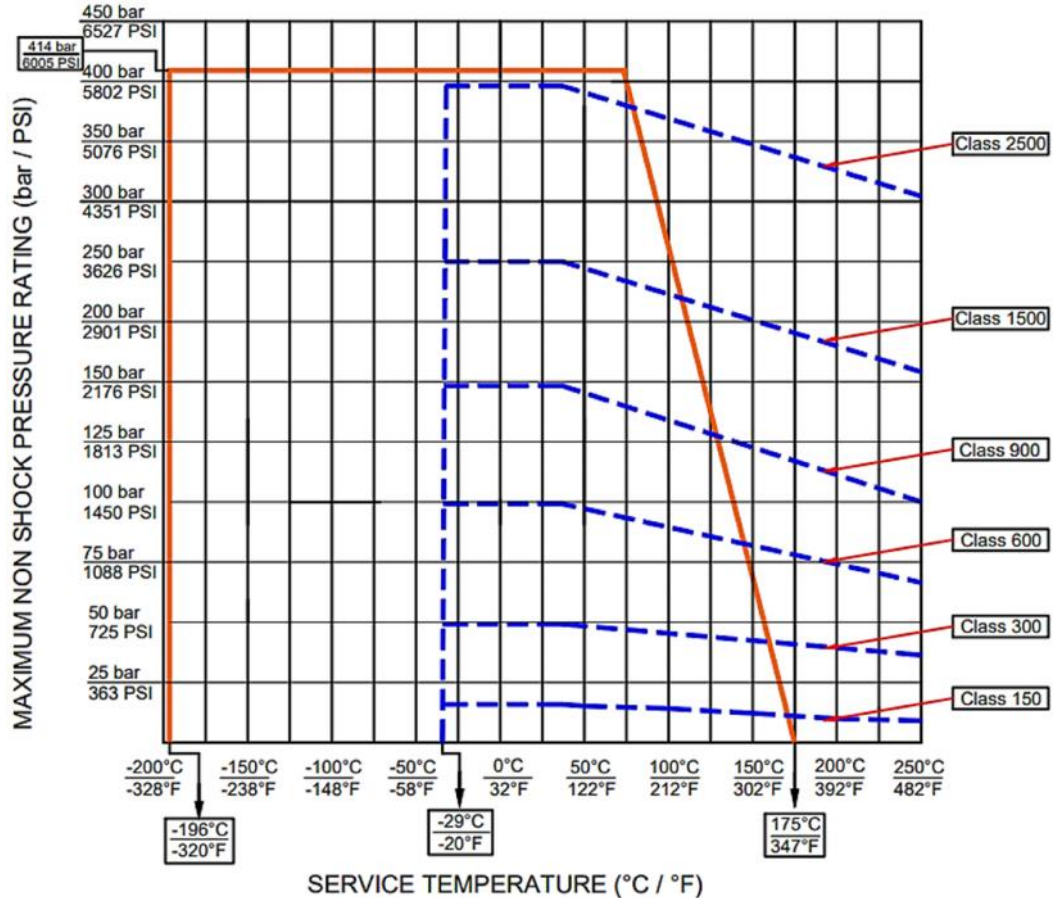



## PCTFE

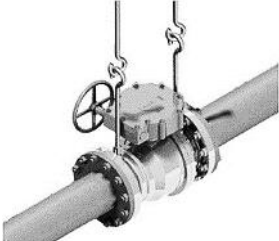

## 6.0 Lifting instructions

Lifting plates are provided for valve weighing 25KG and above unless otherwise specified by the customer. Lifting plates are verified for suitability through design calculations with respect to valve weight along with the operator assembly and accessories. Lifting sketches and handling instructions for safe lifting operation for valves weighing more than 25KG is as shown in the below figures. The safe working Limit (SWL) of each lifting point is marked on the lifting plate. Lifting plates are to be affixed to the valve flange for valves weighing 25KG and above by balancing with respect to center of gravity of the valve along with the valve accessories if any.

	
<p><b>Way of Hosting the Ball Valve</b></p>	<p><b>Avoid this way of Hosting the Ball Valve</b></p>
	
<p><b>Way of Hosting the Ball Valve</b></p>	<p><b>Avoid this way of Hosting the Ball Valve</b></p>
	
<p><b>Valve ready for Disassembling supported on Platform</b></p>	<p><b>Way of supporting the Ball Valve</b></p>
	
<p><b>Way of supporting the Ball Valve</b></p>	<p><b>Way of supporting the Ball Valve</b></p>

## Method of Lifting for Actuated Ball Valves

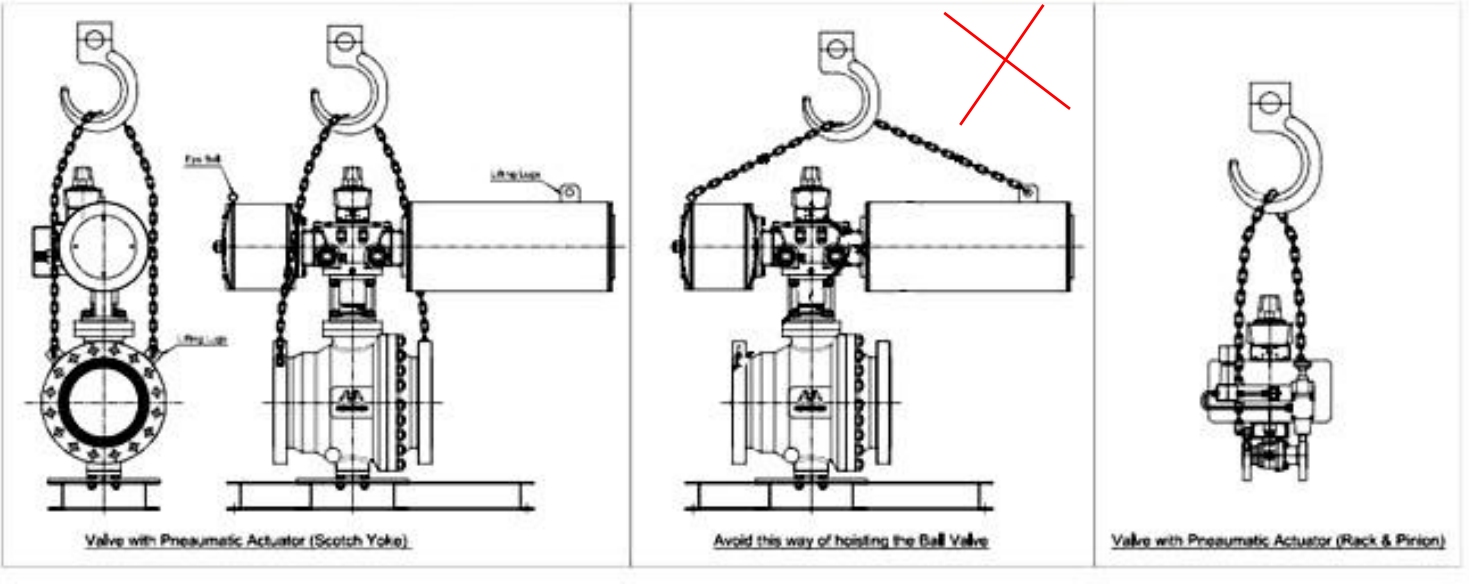

## Method of Lifting for Fire Jacketed Ball Valves

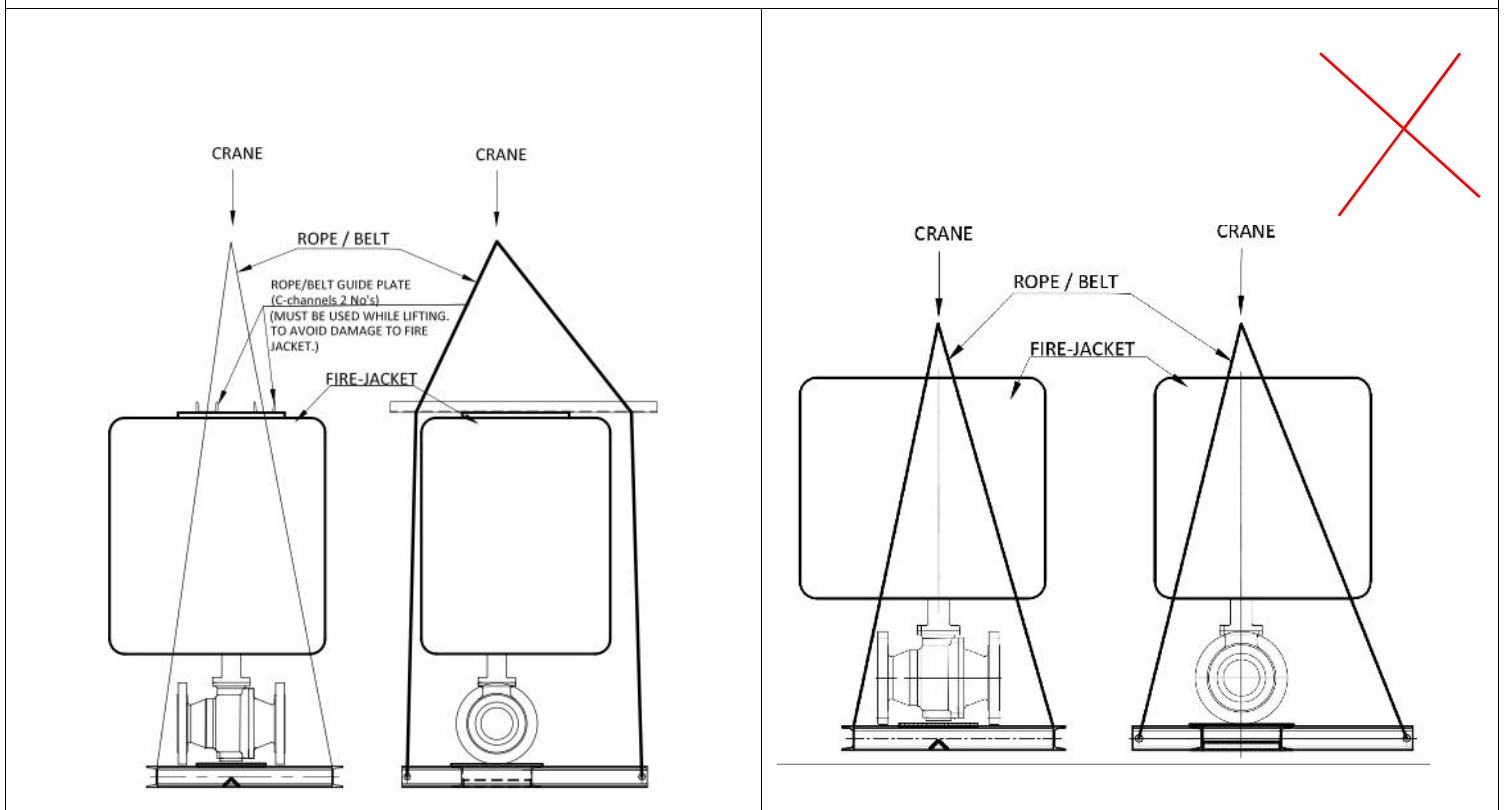

## Lifting arrangement for Fire Jacketed Ball Valves

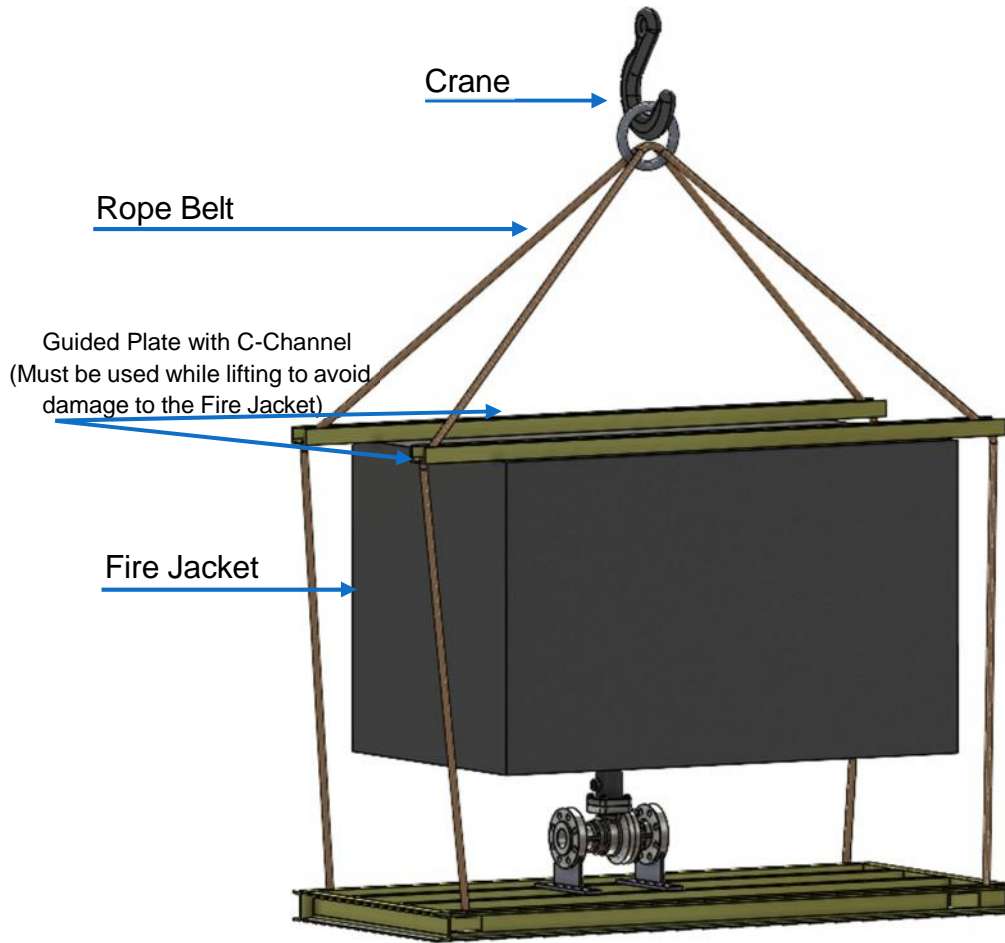

## Method of Lifting for canopy arrangement Ball valve

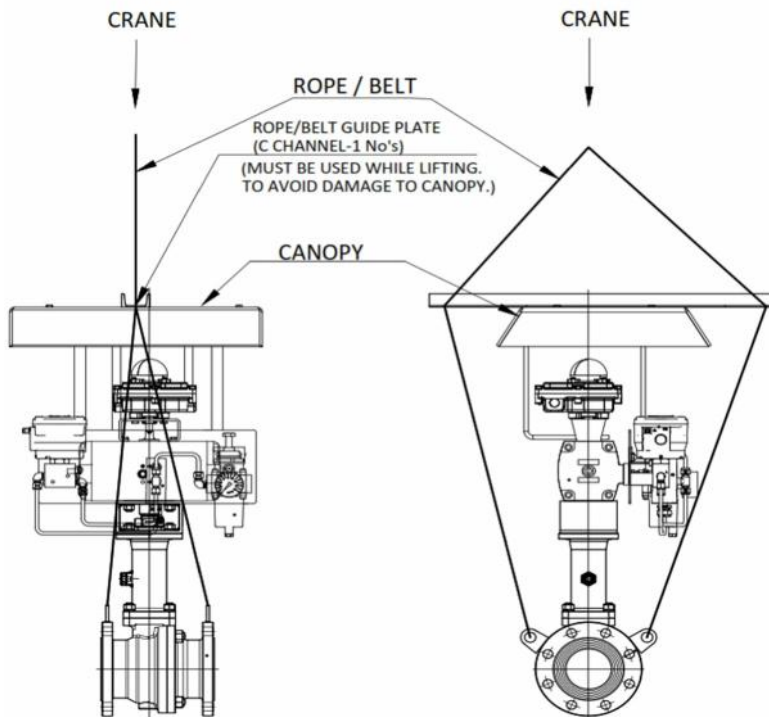

# Ball Valve lifting arrangements, Centre of gravity of valve with different operators

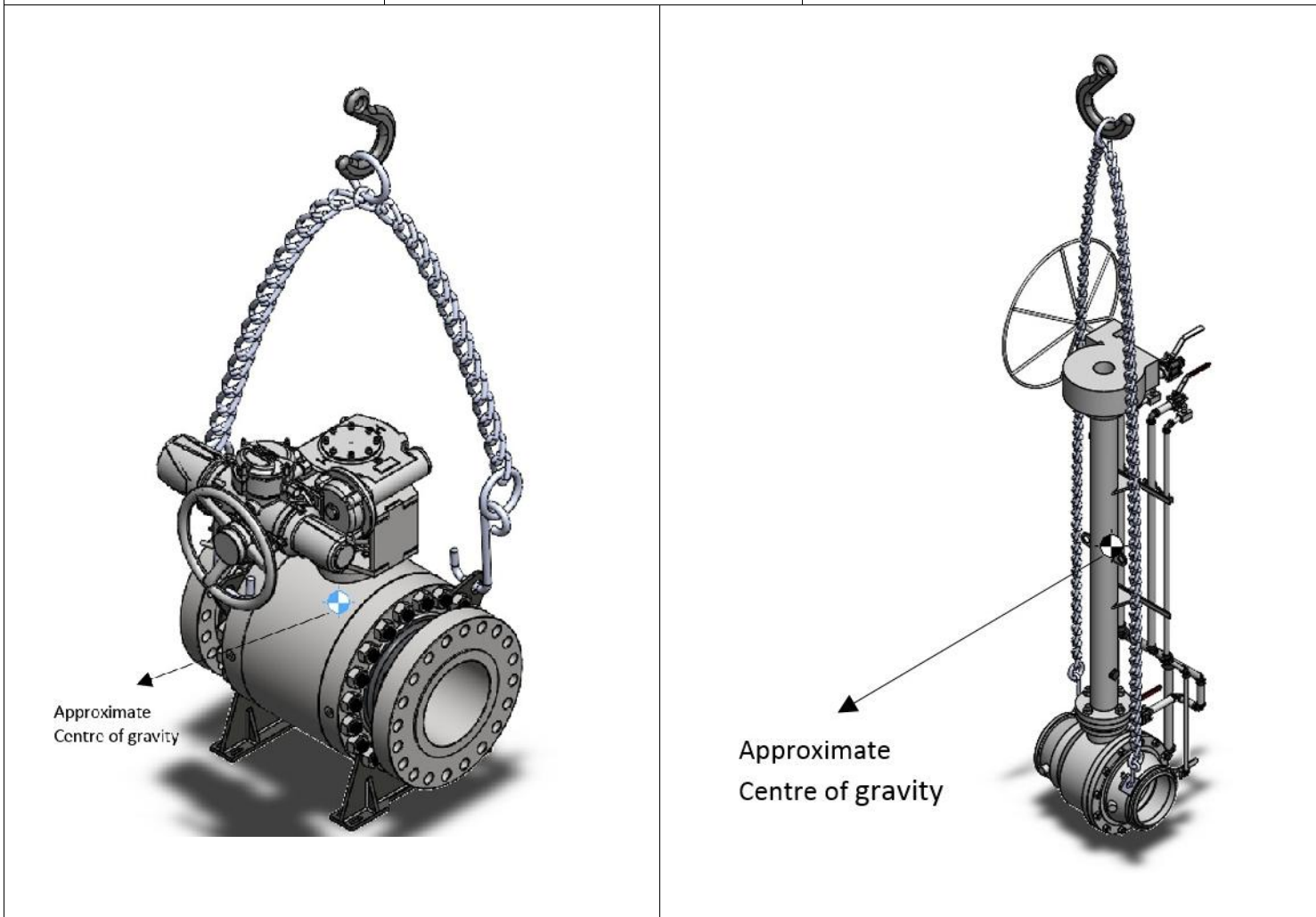
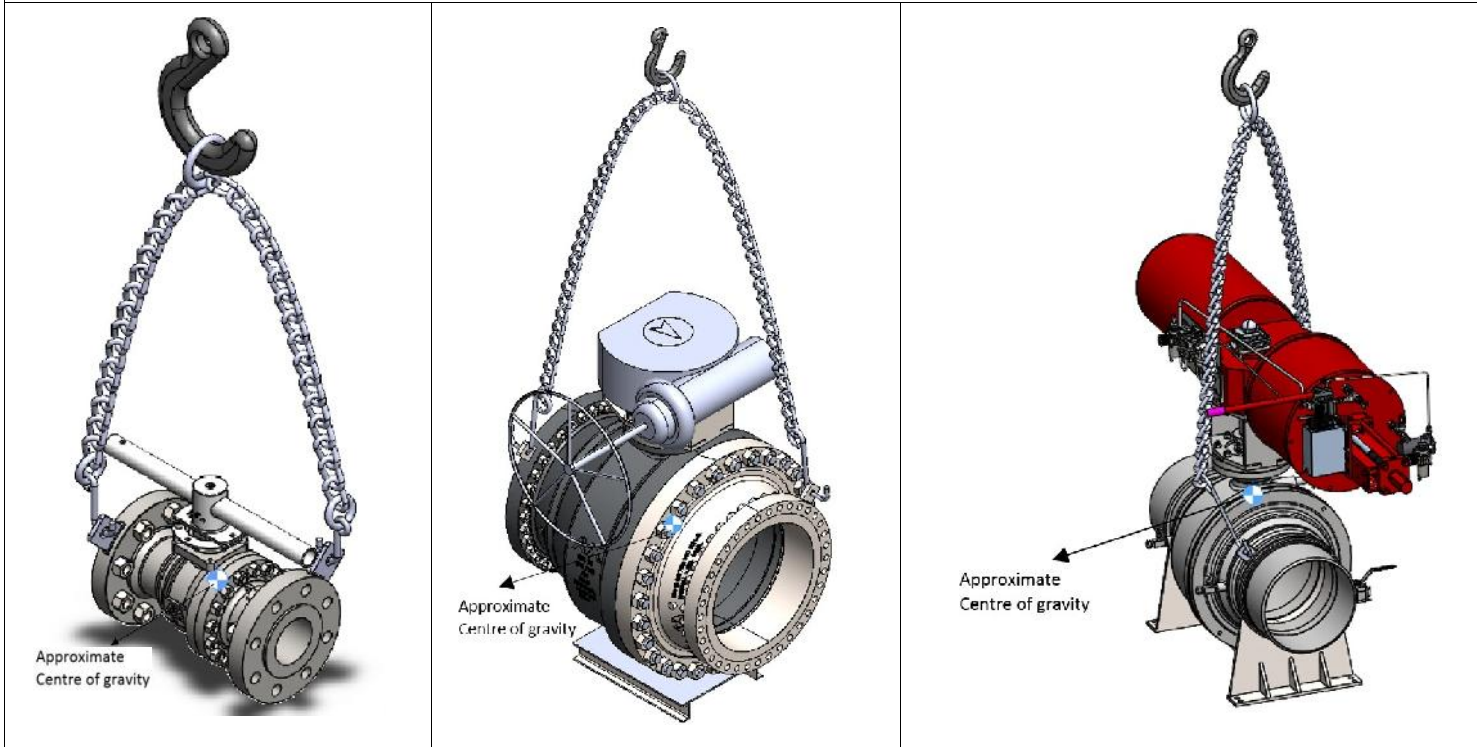

➤ **Instruction for lifting the valve assembly**

Valve shall be lifted using the lifting lugs provided on the valve. Eye bolts provided on the actuator shall not be used for lifting the entire valve – actuator assembly. Eye bolting actuator shall be used only for lifting the actuator during maintenance if any.

Along with the lifting lugs provided on the valve, eye bolts provided on the actuator may also be used for balancing if needed while lifting.

While lifting the valve assembly care should be taken to see that the tubing and accessories mounted on the valve and actuator are not damaged.

**CAUTION:** Please read the instructions carefully and completely before installation. Microfinish does not take responsibility for any kind of damage occurred due to mishandling the valve. Valve must be installed, used, repaired in accordance with the installation and operation instructions

## TROUBLESHOOTING

Sl.No.	Nature of Defect	Cause	Remedy
1	Seat Leakage	<ol style="list-style-type: none"> <li>1. Damage of Seat due to presence of foreign particles.</li> <li>2. Damage of 'O' Ring at the seat/retainer.</li> <li>3. Damage of seat in weld end valves due to improper precautions.</li> <li>4. Damage of seat at high temperature.</li> <li>5. Improper closing of actuator operated valves.</li> <li>6. Damage of seat due to rust at body of seat retainer.</li> </ol>	<p>Dismantle, clean &amp; replace by new seats</p> <p>Dismantle, clean &amp; replace by new 'O' Rings</p> <p>Suggest following right steps as per IOM manual.</p> <p>Check for suitability of seat material and design.</p> <p>Ensure correct closing of actuator.</p> <p>Dismantle, clean &amp; reassemble/replace.</p>
2	Gland Leakage	<ol style="list-style-type: none"> <li>1. Loosening of check nut or locking bolt.</li> <li>2. Damage of stem seal/stem washer</li> <li>3. Misalignment of actuator, bracket&amp; stem.</li> </ol>	<p>Tighten the check nut &amp; locking bolts</p> <p>Replace the stem seal/stem washer.</p> <p>Ensure correct alignment.</p>
3	Body Seal Leakage	<ol style="list-style-type: none"> <li>1. Improper tightening of Body bolting.</li> <li>2. Improper precautions in case of weld end valves.</li> <li>3. Misalignment of pipe line mating flanges.</li> </ol>	<p>Ensure proper tightening of Body bolting.</p> <p>Suggest following right steps as per our IOM manual.</p> <p>Ensure correct alignment of flanges.</p>
4	High Torque operation	<ol style="list-style-type: none"> <li>1. High temperature of fluid handled.</li> <li>2. Highly viscous fluid handled.</li> <li>3. Insufficient air supply pressure incase of pneumatic operated valves</li> <li>4. Reducing of lever length by user due to less space.</li> <li>5. Pipeline flange pressure in case of single piece valves.</li> </ol>	<p>Check for suitability of material and design.</p> <p>Check for suitability of material and design.</p> <p>Ensure sufficient air pressure.</p> <p>Suggest using levers of correct length.</p> <p>Face the seat or seat seal to relieve extra pressure.</p>
5	Jerky operation	<ol style="list-style-type: none"> <li>1. Presence of foreign particles at seat contact area.</li> <li>2. Peeling of plating of Ball in case of metal seated valves.</li> <li>3. Insufficient air supply pressure incase of pneumatic operated valves</li> </ol>	<p>Dismantle, Clean &amp; Reassemble.</p> <p>Check for service condition/replace.</p> <p>Ensure sufficient air pressure.</p>
6	Gear Operator Damage	<ol style="list-style-type: none"> <li>1. Very high torque operation.</li> <li>2. Poor material of construction &amp; design.</li> <li>3. Transit damage.</li> </ol>	<p>Check for causes as covered in SI.No.4</p> <p>Check for suitability.</p> <p>Replace the damaged spares &amp; report accordingly.</p>